

**DC-12.5G18G-20-S** is a  $20\pm 1\text{dB}$  coupling directional coupler, designed to operate over the 12.5 to 18.0 GHz frequency range, with compact size. This model is designed to handle 50W mx input power, and also performs with low insertion loss of 0.5dB max and with coupling flatness of  $\pm 0.5\text{dB}$  max, and low VSWR of 1.4 max.

### Mechanical Outline(Inch/mm):

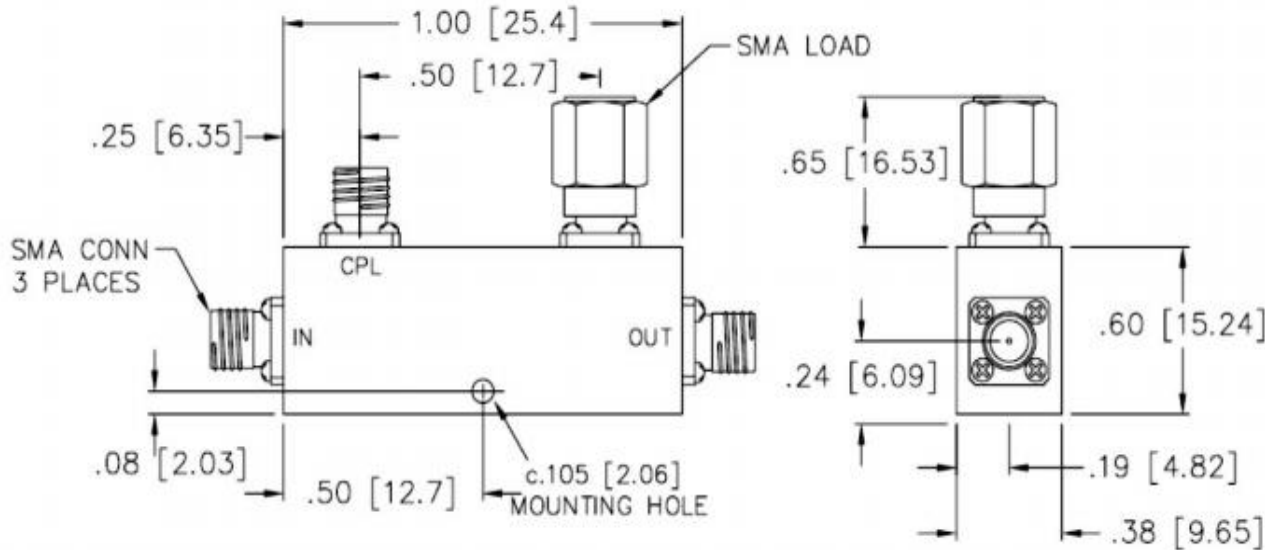

### Specifications:

Coupling:	20±1dB
Frequency:	12.5 to 18.0 GHz
Insertion Loss:	0.5dB max
Coupling flatness:	±0.5dB max
Directivity:	15dB min
Power Handling:	50W max
VSWR:	1.4:1 max
Connectors:	SMA-F(N optional)

### Environmental Ratings:

Temperature:	-25°C to +71 °C Operating -65 °C to +100 °C Non-Operating
Vibration:	MIL-STD-202F, Method 204D Cond. B
Altitude:	MIL-STD-202F, Method 105C Cond. B
Temperature Cycle:	MIL-STD-202F, Method 107D Cond. A

Directional Coupler DC-12.5G18G-20-S			
DRAWN:	DWG NO.:	REV CODE: Rev.1.0	 <a href="http://www.connphy.com">www.connphy.com</a> <a href="mailto:sales@connphy.com">sales@connphy.com</a>
CHECKRD:	DATE: 18/04/15	SHEET : 1 OF 1	
ISSUED:	SIZE: A	SCALE : N / A	Notes: SPEC ARE SUBJECT TO CHANGE WITHOUT NOTICE.